

## 1200lbs Water Proof Electromagnetic Lock

Model ML-SS-1200GL (Monitored Version)

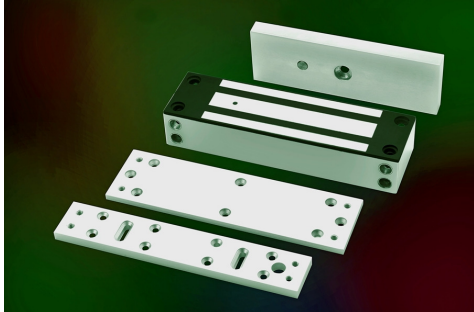

### Description

1200lbs Water Proof EM locks were designed as such to be unaffected / resisting the ingress of water under specified condition with its fully sealed electronics incased with stainless steel. Suitable for outdoor application and harsh climate.

### Standard Features



Fail Safe

Life Safety Applications



Zero Residual Magnetism

No Residual



Low Power

Low Energy Consumption



Low Maintenance

Cost Savings

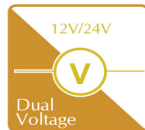

12V/24V

Dual Voltage

12/24V Selectable



Waterproof

Fully Sealed Electronics

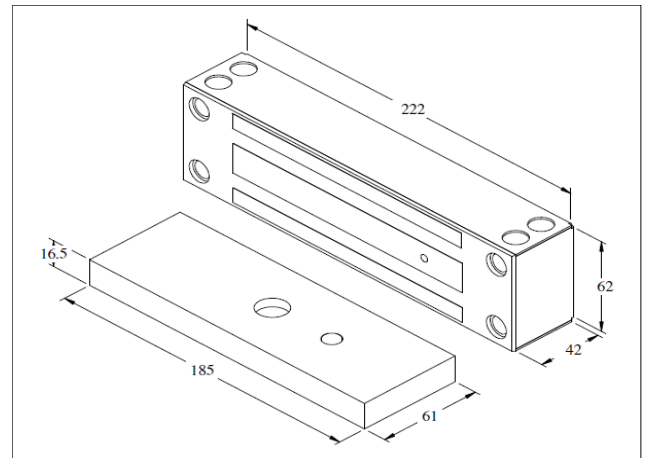

### Features & Technical Specification

Models	ML-SS-1200GL
Features & Spec.	
Lock Status Monitoring	Reed Switch
Holding Force	Up to 1200lbs
Magnet Size	222 X 62 x 42 mm
Armature Size	185 X 61 X 16.5 mm
Current Drain	420mA±10%/12Vdc / 210mA±10%/24Vdc
Temperature	(-10 to 55)°C (14 to 131)°F
Housing	Stainless Steel Housing
Weight	5.26 Kg

### Wiring Diagram

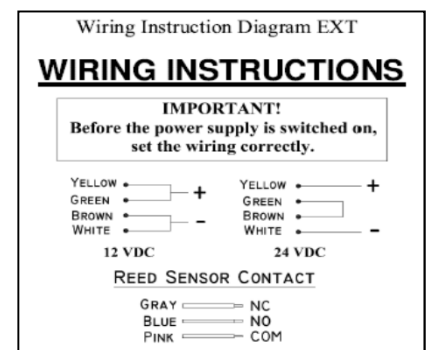

**DISCLAIMER:-** Specifications are subject to change without prior notice.

- Attached photo is for reference purpose only, actual product may varies.